



PROLINE PAN

PLPAN26, PLPAN27.5, PLPAN30,
 PLPAN33, PLPAN36, PLPAN40,
 PLPAN44, PLPAN46, PLPAN48,
 PLPAN52, PLPAN57, PLPAN63,
 PLPAN68

TECHNICAL SPECIFICATION

Job Name _____	Item # _____
Location _____	
Engineer _____	Contractor _____
PO # _____	Tag _____
Representative _____	

DESCRIPTION

ProLine pan—Tileable shower receptor for Linear Drain —is made of extruded rigid PET (polyethylene terephthalate) plastic foam. It is strong yet lightweight, non-reactive, economical, and shatterproof.

- Chemically stable, UV resistant and suitable for both interior and exterior use
- Can be used with both sheet and liquid topical waterproofing
- Speed and consistency of installation
- Eliminates the need for traditional mud bed installations
- Lightweight, durable with high compressive strength 145PSI
- Interlocking design, can be quickly and easily modified to size and shape of on site conditions
- Meets IAPMO PS-106-2013
- 100% post Consumer recycled and fully recyclable. ♻️
- Custom curb sizes available

APPLICATIONS / USES

- Interior and exterior use
- Industrial, commercial and residential showers
- Gang showers
- Pet Showers

SUITABLE SUBSTRATES (INTERIOR ONLY)

- Concrete
- Exterior Glue Plywood
- Cement backer board**
- OSB Or Avantech

**Consult cement backer board manufacturer for specific installation recommendations

PROLINE PAN INCLUDES

- Flat Panel (SLFP1760)
- Drain Support Frame*
- Quick Slope (SLQS1652**, SLQS852***)
- Curb (SL Curb)
- Screws (5)

APPROVALS AND LISTINGS

Before installing QuickDrain USA system, check with your local building department/plumbing inspector to ensure compliance with the local building codes. QuickDrain USA LLC is not responsible for any conflicts with local building codes. QuickDrain USA LLC is not responsible for improper installation of any part of the assembly or the waterproofing membrane. Dimensions are subject to manufacturer's tolerance and can change without notice.



PLPAN	*DSF	**SLQS1652	***SLFP1760
PLPAN26	PLDSF26	2	-
PLPAN27.5	PLDSF27.5	2	-
PLPAN30	PLDSF30	2	1
PLPAN33	PLDSF33	2	1
PLPAN36	PLDSF36	2	1
PLPAN40	PLDSF40	3	-
PLPAN44	PLDSF44	3	-
PLPAN46	PLDSF46	3	1
PLPAN48	PLDSF48	3	1
PLPAN52	PLDSF52	3	1
PLPAN57	PLDSF57	4	-
PLPAN63	PLDSF63	4	1
PLPAN68	PLDSF68	4	1



PROLINE PAN

PLPAN26, PLPAN27.5, PLPAN30,
 PLPAN33, PLPAN36, PLPAN40,
 PLPAN44, PLPAN46, PLPAN48,
 PLPAN52, PLPAN57, PLPAN63,
 PLPAN68

TECHNICAL SPECIFICATION

DIMENSIONS (CURB) SLCURB

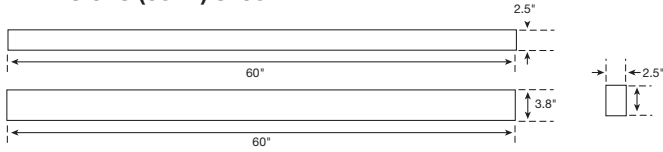

DIMENSIONS (QUICK SLOPE) SLQS1652, SLQS852

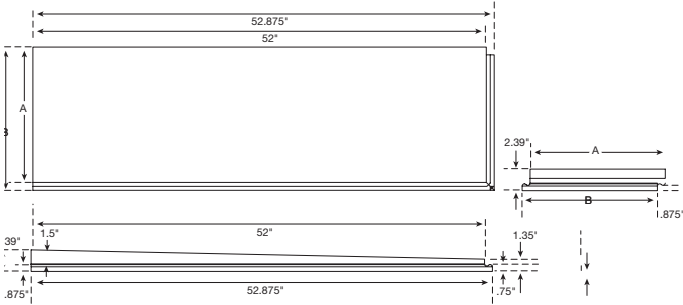

MODEL	A	B
SLQS1652	16"	16.875"
SLQS852	8"	-

DIMENSIONS (DRAIN SUPPORT FRAME)

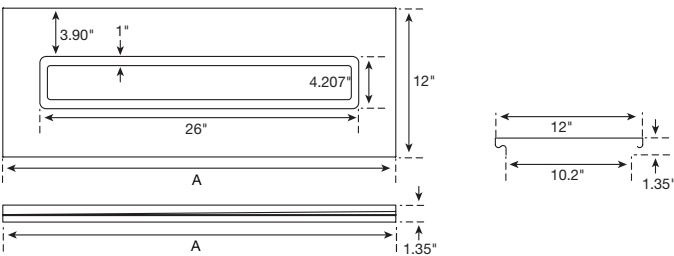

MODEL	A
PLDSF26	32"
PLDSF27.5	32"
PLDSF30	40"
PLDSF33	40"
PLDSF36	40"
PLDSF40	48"

DIMENSIONS (FLAT PANEL) SLFP1760

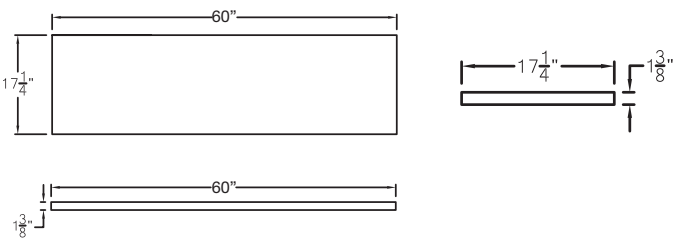

PLDSF44	48"
PLDSF46	56"
PLDSF48	56"
PLDSF52	64"
PLDSF57	64"
PLDSF63	72"
PLDSF68	72"