



SPECIFICATIONS

Rectangular Shower Seats
Folding, Phenolic or Padded

DESCRIPTION

Seats meet Fed Spec. WW-P-541/8b, Amendment 1.16 April, 1990, ANSI A117.1 and ADA 2010. When properly installed, exceeds all applicable federal load specifications. Folding seat with swing down legs has adjustable rubber feet and friction in the fasteners of the SST cross member holds seat in upright position.

LOAD CAPACITY

When properly installed, a fold down seat with legs has a load capacity of 900 lbs.

DIMENSIONS AVAILABLE (seat top surface)

22" x 13.5"

28" x 13.5"

32" x 13.5"

34" x 13.5"

41" x 13.5"

43" x 13.5"

48" x 13.5"

(Phenolic top = 18" tall / Padded top = 19" tall)

CONSTRUCTION

Frame: Type 304 (18-8) SST tubing, 1-1/4" (32mm) x 18 ga. (1.2mm) square main frame with 1" (25mm) x 18 ga. (1.2mm) round cross members.

Wall flanges: Type 304 (18-8) SST 10 ga. (3.4 mm) x 3" (76mm) diameter, heliarc welded to 1" (25mm) supports, and to 1-1/4" (32mm) round x 12 ga. (2.7mm) frame hinge couplings. Three mounting holes per flange.

Seat Surface: Seat surfaces are attached with SST screws.

- Phenolic, solid white 1/2" (13mm) thick with rounded edges.
- Padded, 2" (51 mm) white naugahyde encapsulating marine plywood and foam padding.

INSTALLATION

All shower seats must only be installed using sufficient in-wall backing material. If additional blocking is required add 8"x8" (minimum) block centered behind mounting flange at both mounting locations. Mounting height may vary due to 1.5" adjustability in seat foot.

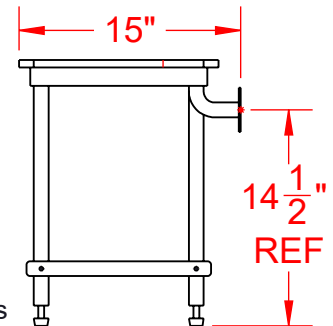
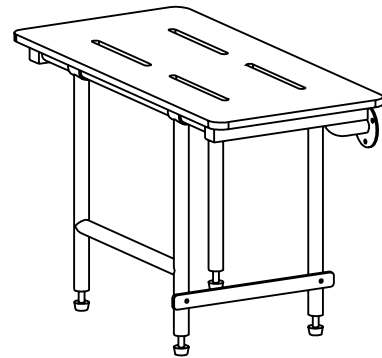

PHENOLIC with legs

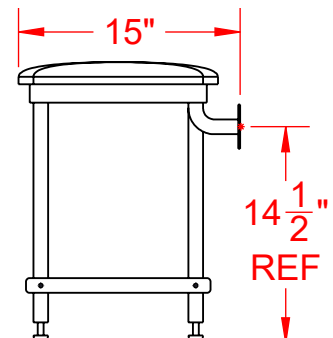
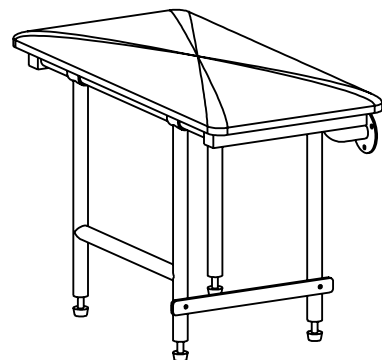

PADDED with legs