

MODEL: 4LBS4038A5B* L/R

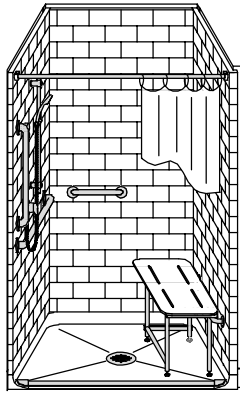

*ALL ACCESSORIES OPTIONAL



PERSPECTIVE VIEW - N.T.S.
 MODEL SHOWN HERE AS:
 LEFT PLUMBING
 RIGHT SEAT
 RIGHT REVEAL

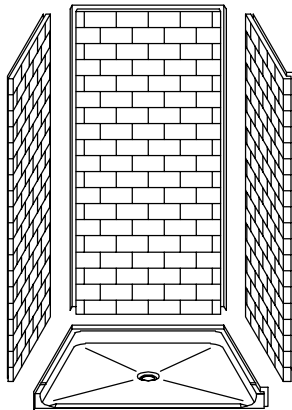
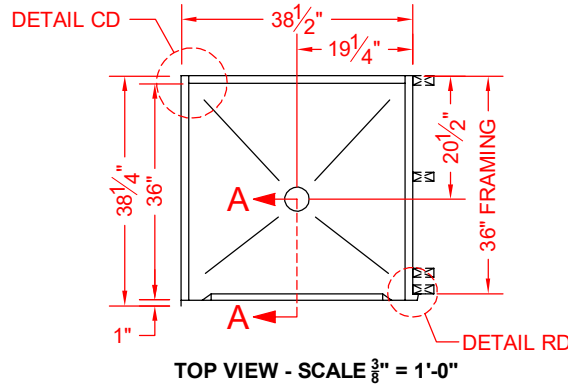

ASSEMBLY VIEW - N.T.S.

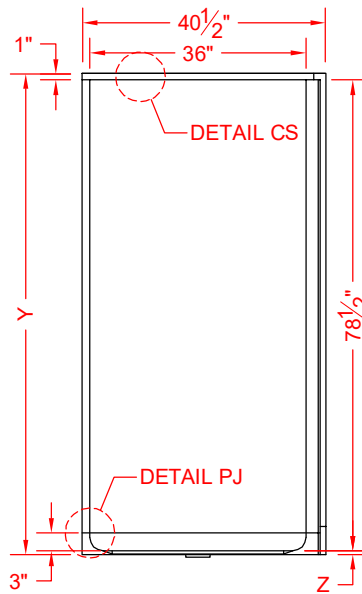

Features:

- ADA compliant four-piece transfer shower
- Molded gelcoat/fiberglass shower module
- "Subway Tile" 4"x8" wall finish, white (standard)
- Integral full wood backing for strength and unlimited accessory placement
- Available in various threshold heights
- On all threshold heights 1-1/4" or shorter, no mud set is required and an anchoring adhesive kit is supplied
- On all threshold heights 1-1/2" or taller, no mud set is required

*OTHER THRESHOLD HEIGHTS AVAILABLE UPON REQUEST

MODEL #	UNIT	THRESHOLD
	HEIGHT	HEIGHT
4LBS4038A5B	Y	Z*
4LBS4038A2B	80-1/8"	5/8" MIN.
	81-1/2"	2" MAX.

* - SEE BACK FOR DETAIL SECTIONS

PRODUCT SPECIFICATIONS:

- Multi-piece shower module shall be constructed of gelcoat/fiberglass with full integral plywood backing
- Rough-In: Stud opening +1/4" -0" Nominal Dimensions.

C.S.I. FORMAT SPECIFICATION TEXT AVAILABLE

PRODUCT INFORMATION:

- Accessories: Factory installed, unless prone to damage during installation/shipping. Polished chrome/satin stainless standard, others available.
- Colors: White as standard, others to match any major fixture manufacturer, also available with sprayable solid surface in many colors
- Custom curb heights, other than shown, are available (between min. and max.)

OPTIONAL ACCESSORIES:

INSTALLED BY OTHERS:

- Grab bar
- Seat, folding
- Mixing valve, pressure-balancing, lever handle, pre-plumbed tee to supply elbow
- Curtain and rod
- T-shaped rubber WaterStopper kit
- Semi-permanent threshold adaptor
- No-caulk brass drain

CODES:

- Designed and manufactured in compliance with the following standards and codes:
- ANSI Z124.2 Standards for Plastic Showers
 - ADA Accessibility Guidelines for Buildings and Facilities
 - ANSI A117.1 A - Accessible and Usable Buildings and Facilities
 - ANSI A117.1 B - Accessible and Usable Buildings and Facilities
 - IPC International Plumbing Code
 - UPC Uniform Plumbing Code

NOTICE OF LIMITATION:

- Recess floor as needed to meet code
- Adhere to floor as required



We reserve the right to make revisions without notice in the design of fixtures or in packaging unless this right has specifically been waived at the time the order is accepted.

4LBS4038A5B L/R

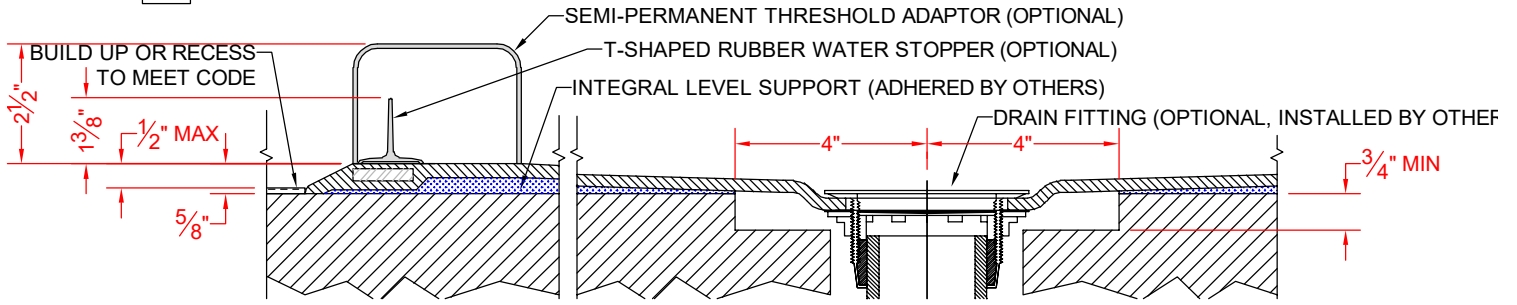

SECTION A-A - SCALE: 3" = 1'-0"

4LBS4038A2B L/R

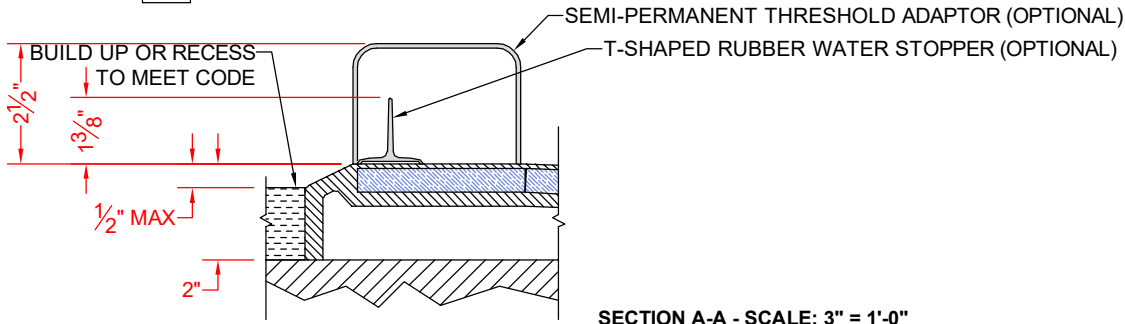

SECTION A-A - SCALE: 3" = 1'-0"

****OTHER THRESHOLD HEIGHTS AVAILABLE UPON REQUEST****

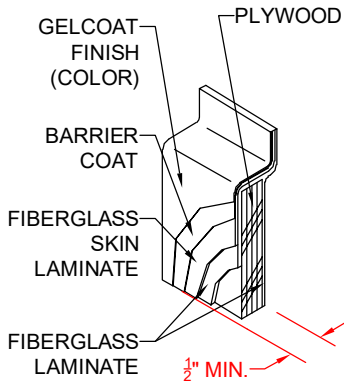

DETAIL CS - SCALE: N.T.S.
CROSS SECTION DETAIL

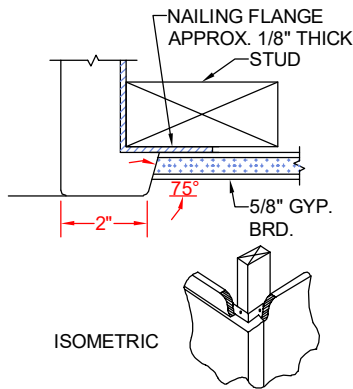

DETAIL RD - SCALE: N.T.S.
REVEAL DETAIL

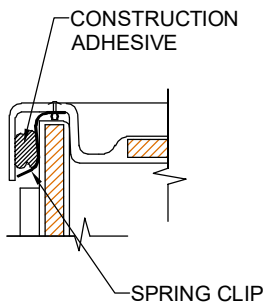

DETAIL CD - SCALE: N.T.S.
CORNER DETAIL

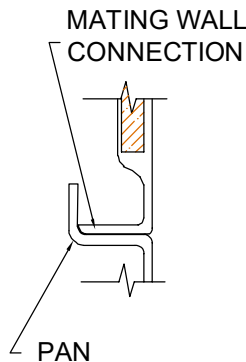

DETAIL PJ - SCALE: N.T.S.
PAN JOINT DETAIL