



AQUA

SHOWER / TUB DOOR INSTALLATION INSTRUCTIONS

IMPORTANT

DreamLine™ reserves the right to alter, modify or redesign products at any time without prior notice. For the latest up-to-date technical drawings, manuals or any other details please refer to the support.BathAuthority.com web page.

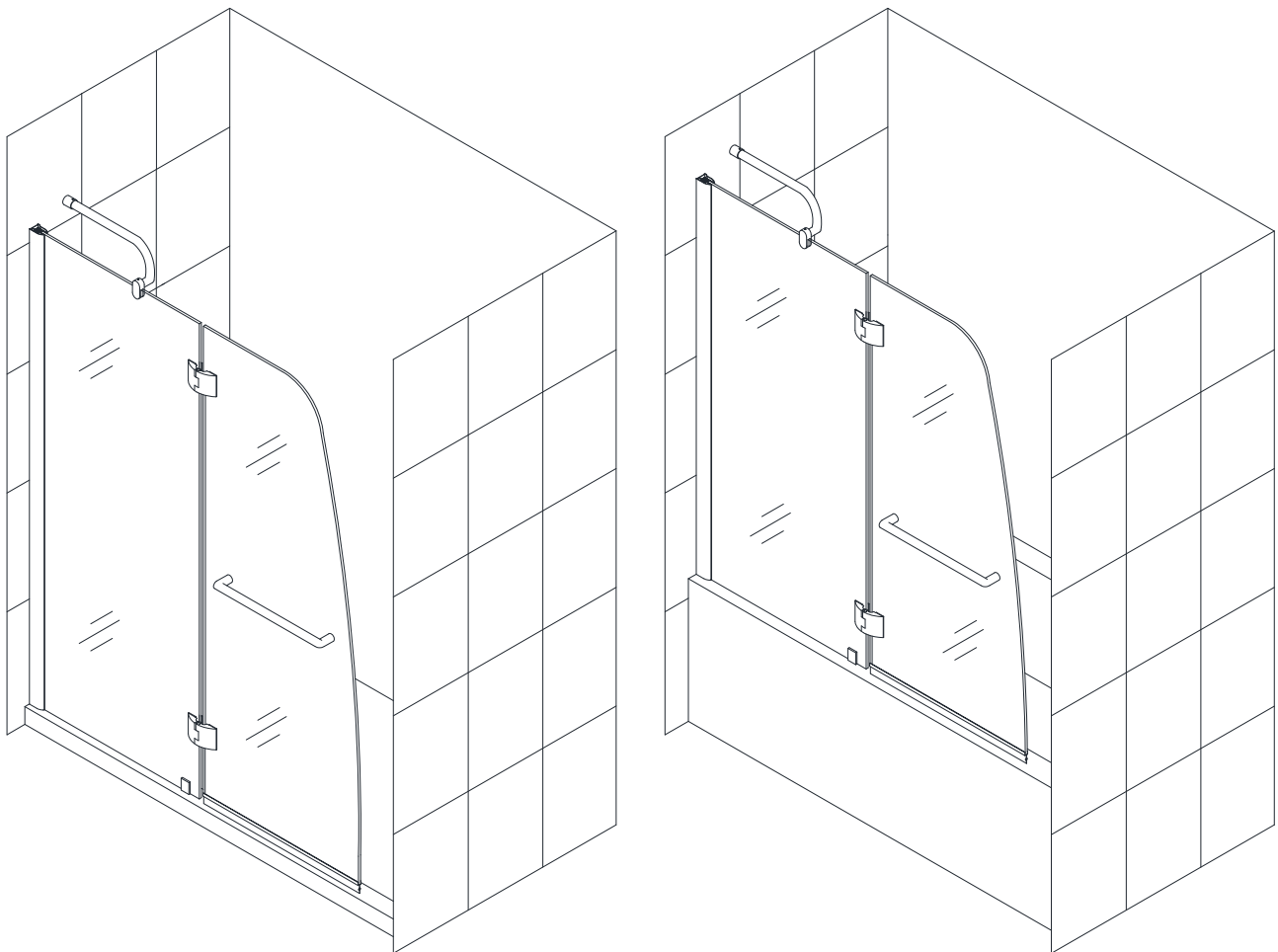

Please carefully read the instructions before installing. If you have any questions regarding installation, please call our technical support specialists Monday through Friday 9:00 AM – 5:00 PM EST at 1-866-731-8378, ext. 3 or e-mail our technical support group at support@BathAuthority.com.

For more information on [DreamLine™ Shower Door](http://www.BathAuthority.com) and [Tub Door](http://www.BathAuthority.com) please visit www.BathAuthority.com

Preparation

1. After opening all boxes and packages, read this introduction carefully. Check that all of the needed parts are included in the package, by marking all the components on the "Detailed Diagram of Shower/Tub Door Components". Examine boxes and packages for shipping damage. If the unit has been damaged, has a finishing defect, or has missing parts, please contact our customer support department within 3 business days of the delivery date. Please note that **DreamLine™ will not replace any damaged products or missing parts free of charge after 3 business days or if the product has been installed.** Feel free to contact DreamLine™ if you have any questions.
2. If this unit is going to be installed in a new construction, please, install all of the required plumbing and drainage before installing the shower. **Use a competent and licensed (if required by local code) plumber for all plumbing installation**
3. **Please note that you should consult your local building codes with questions on installation compliance standards. Building and plumbing codes may vary by location, and DreamLine is not responsible for code compliance standards for your project.**
4. Please insure that prior to the installation the installation surface is leveled and solid and will be able to support the total weight of the unit. Also make sure the walls are at right angles. While some adjustment in leveling of the door is possible, irregular installation surface level or improper angle of side walls will result in serious problems for your installation. Please, note that some adjustments and drilling might be necessary during the installation process.

Tools Required

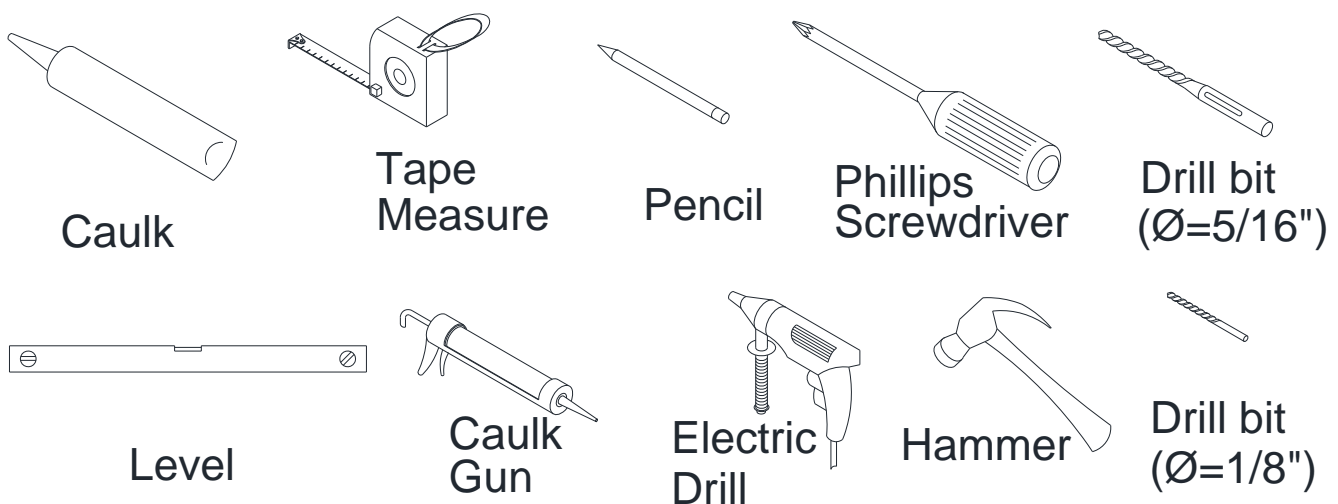

Detailed Diagram of Tub Door Components

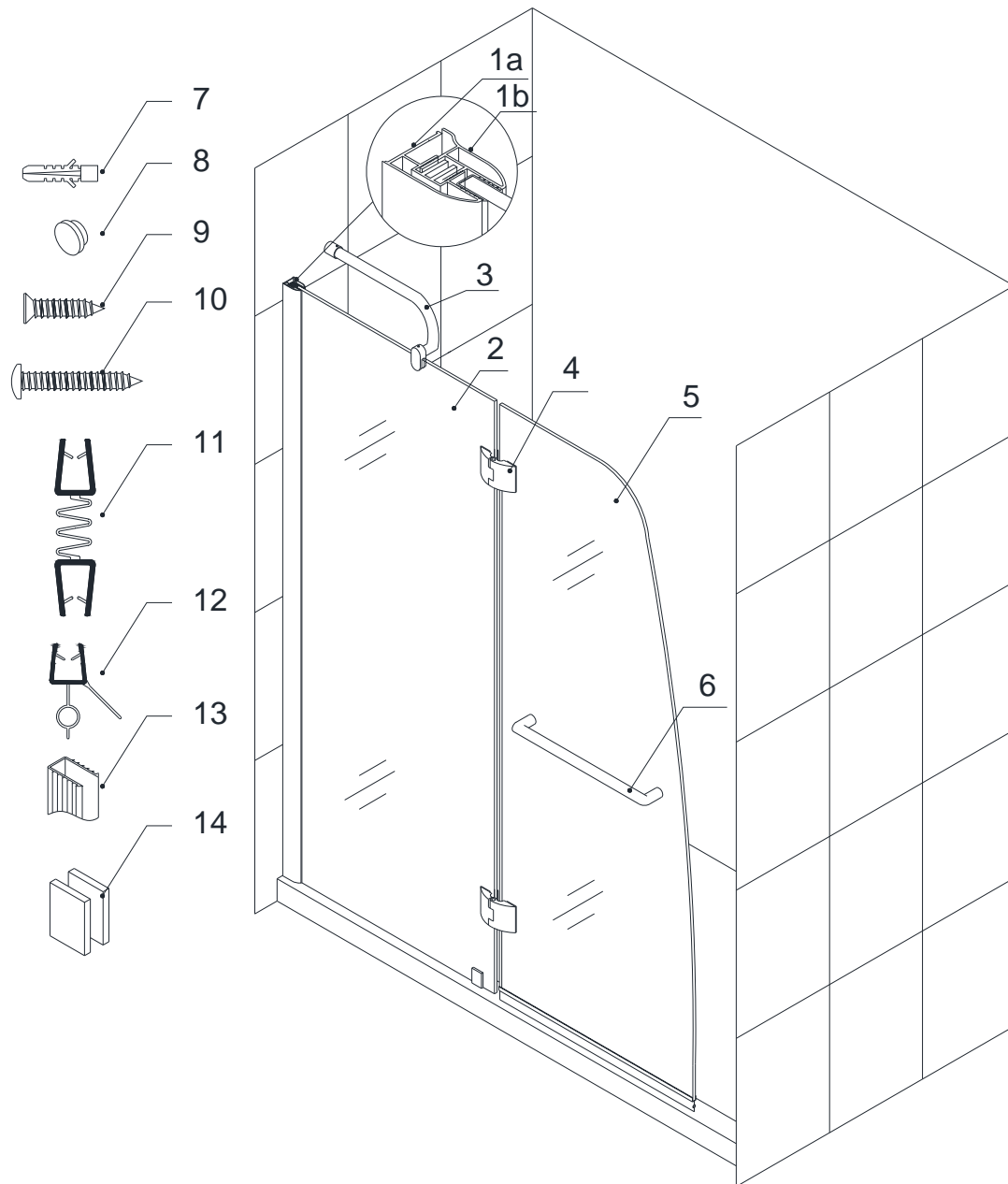

Packing List

01a	Wall profile (External)	1pc	08	Decorative plug	4pcs
01b	Wall profile (Internal)	1pc	09	Countersunk screw ST4.2×15	4pcs
02	Stationary glass	1pc	10	Round head screw ST4.2×30	6pcs
03	Support bar	1pc	11	Connected anti-water strip	1pc
04	Hinge	2pcs	12	Bottom anti-water strip	1pc
05	Glass door	1pc	13	U-shape seal gasket	1pc
06	Handle	1pc	14	Bottom bracket	1pc
07	Wall anchor	5pcs	15	Screw cover	1pc

NOTE: Unpack your unit carefully and inspect it. Lay it out and identify all parts using the detailed diagram and packing list in your manual as a reference. Before discarding the carton, check for small hardware bags that tend to fall to the bottom of the box. If any parts are damaged or missing, please contact DreamLine™ for replacement.

Shower/Tub Door Installation

1. Place the **Wall profile (External) (01a)** to the wall above the Shower base or Tub and level it vertically.

See Fig. 1 for details.

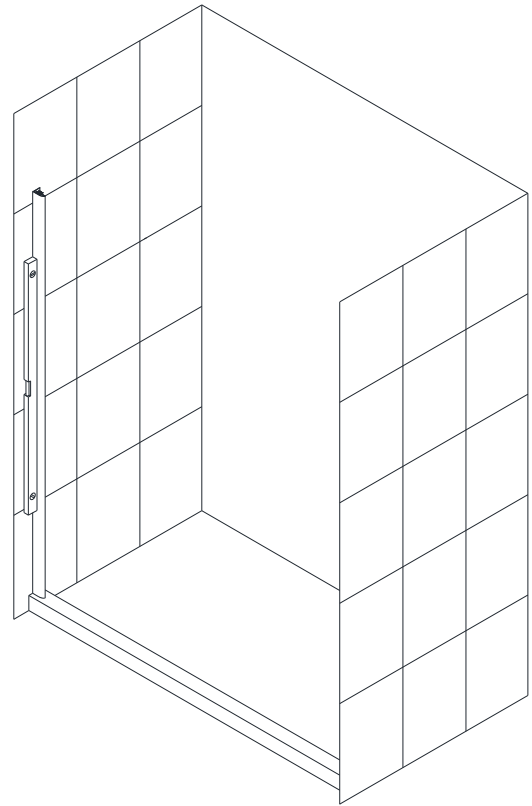

Fig. 1

2. Mark the drilling holes on the wall through the holes in the **Wall profile (External) (01a)**.

Place the **Wall profile (External)** aside, drill the holes using $\text{Ø}5/16''$ drill bit and insert the **Wall anchors (07)**.

Apply silicone caulk along the wall profile and around the holes on the wall.

Place the **Wall profile (External)** back into the designated position and secure it to the wall using the **Round head screws ST4.2×30 (10)**.

See Fig. 2 for details.

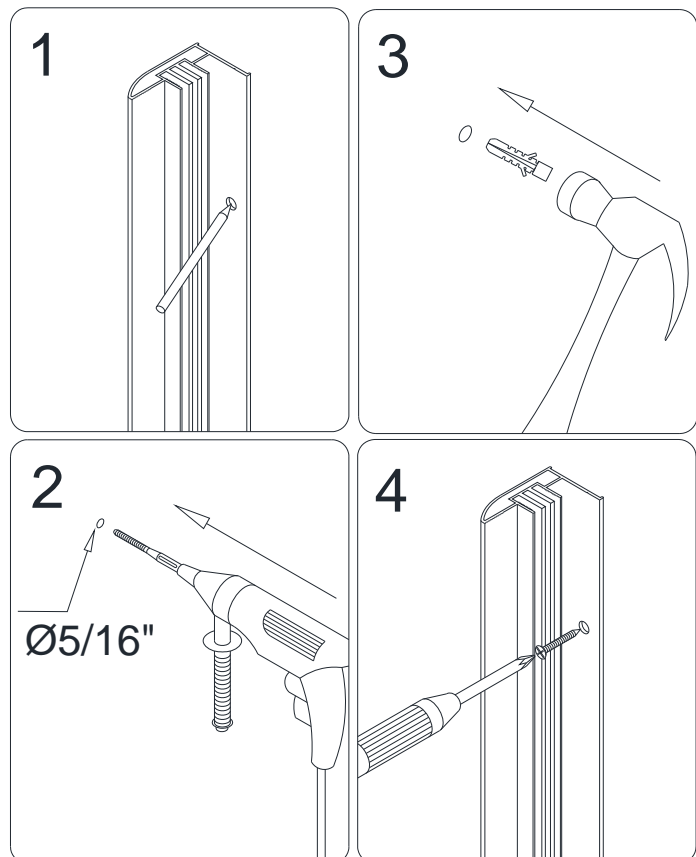

Fig. 2

3. Push **U-Shape seal gasket (13)** over the vertical edge of the **Stationary glass (02)**.

Place the **Stationary glass** with attached **U-Shape seal gasket** onto the Shower base and slide it into the **Wall profile (External) (01a)**.

Attach the **Wall profile (Internal) (01b)** to the **Wall profile (External)** and the **Stationary glass** using **Countersunk screws ST4.2×15 (09)**.

Level the **Stationary glass** vertically and fasten the screws.

See Fig. 3 and Fig. 4 for details.

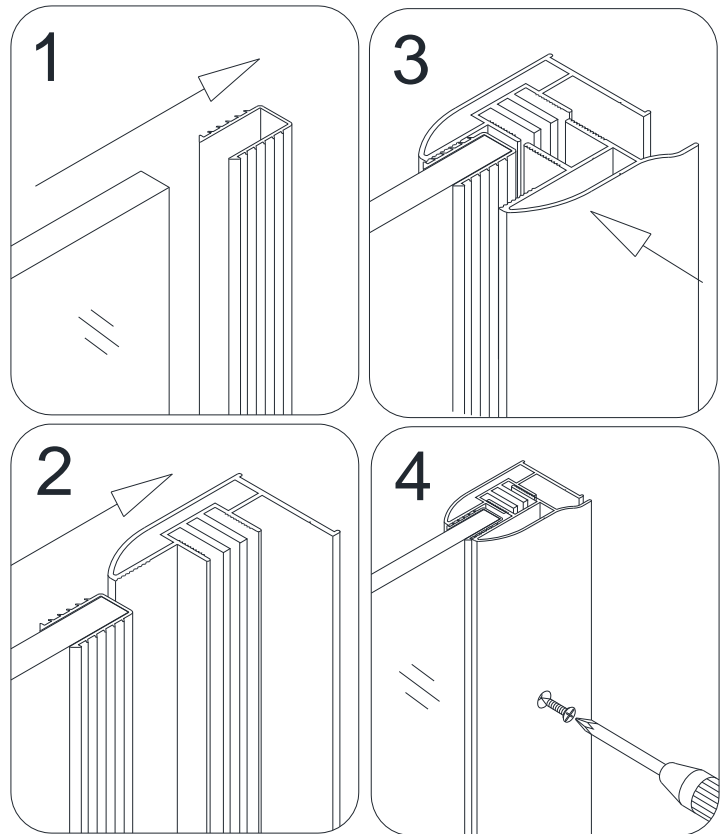

Fig. 3

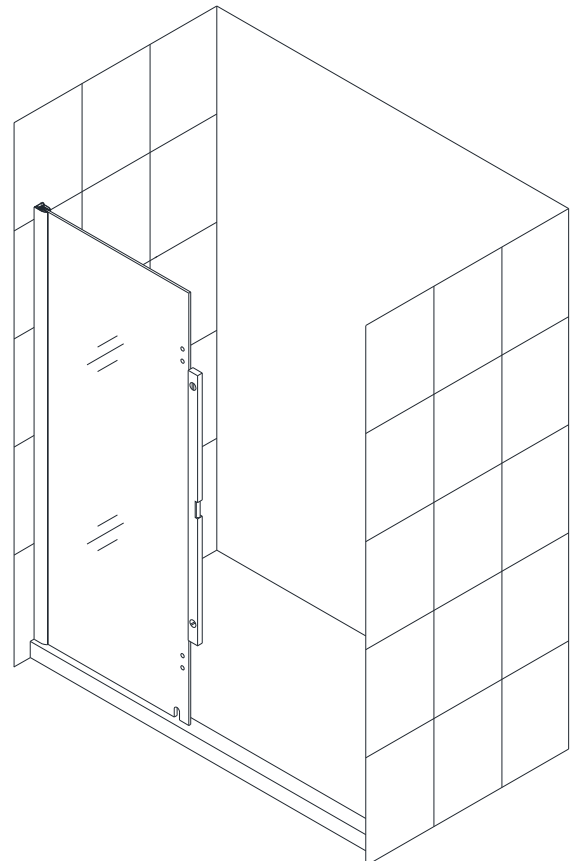

Fig. 4

4. Take apart the **Bottom bracket (14)**, place the mounting part into the U shape hole on the **Stationary glass (02)** from inside and mark the drill hole on the threshold, tray or bathtub.

Remove the glass, drill the hole using $\text{Ø}1/8''$ drill bit and secure the mounting part of the **Bottom bracket** with **Round head screw ST4.2×30(10)**.

See Fig. 5 for details.

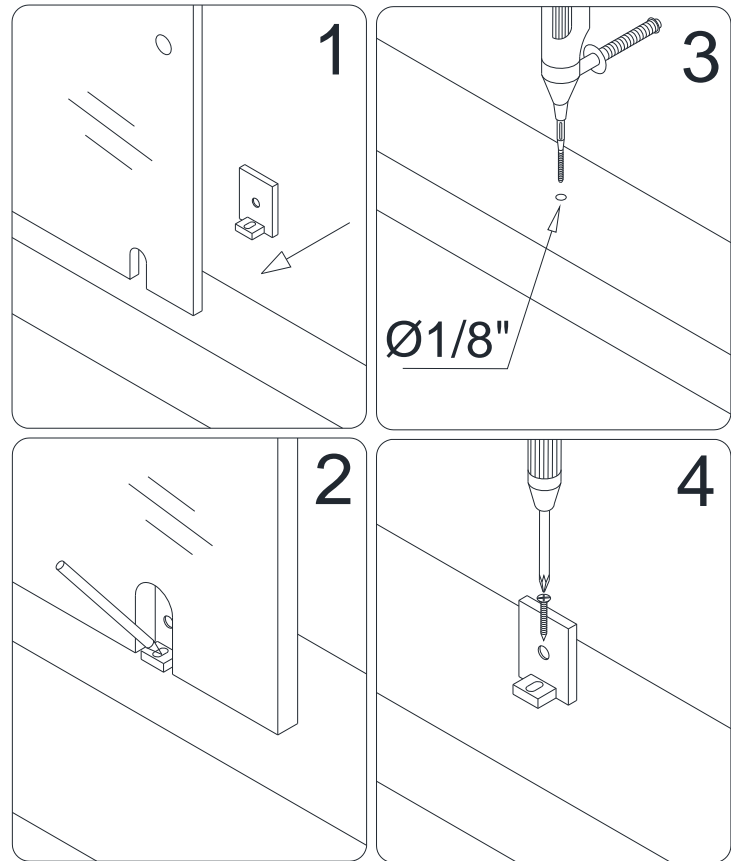

Fig. 5

5. Place the **Stationary glass (02)** back into the **Wall profile**. Assemble the **Bottom bracket (14)**. Fasten tight the **Stationary glass (02)** in the **Wall profiles** and cover screw holes with **Decorative plugs (08)**.

See Fig. 6 and Fig. 7 for details.

NOTE: Make sure to use clear rubber gasket to prevent glass to metal connection.

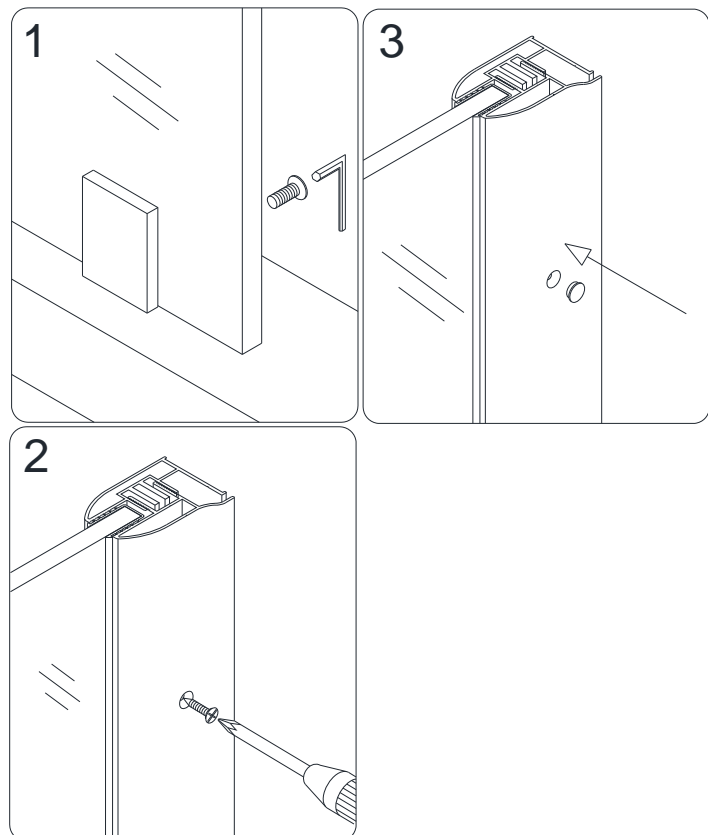

Fig. 6

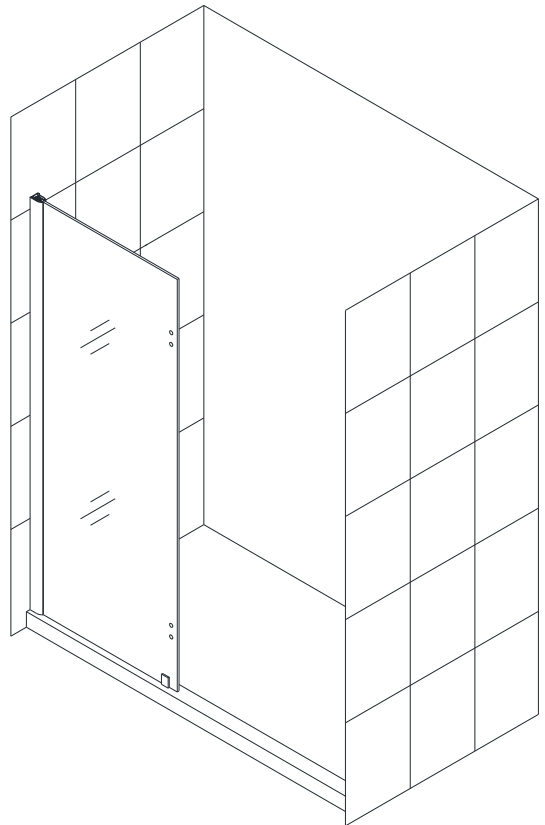

Fig. 7

6. Mark the hole for the **Support bar (03)** on the wall according to the measurements.

See Fig. 8 for details.

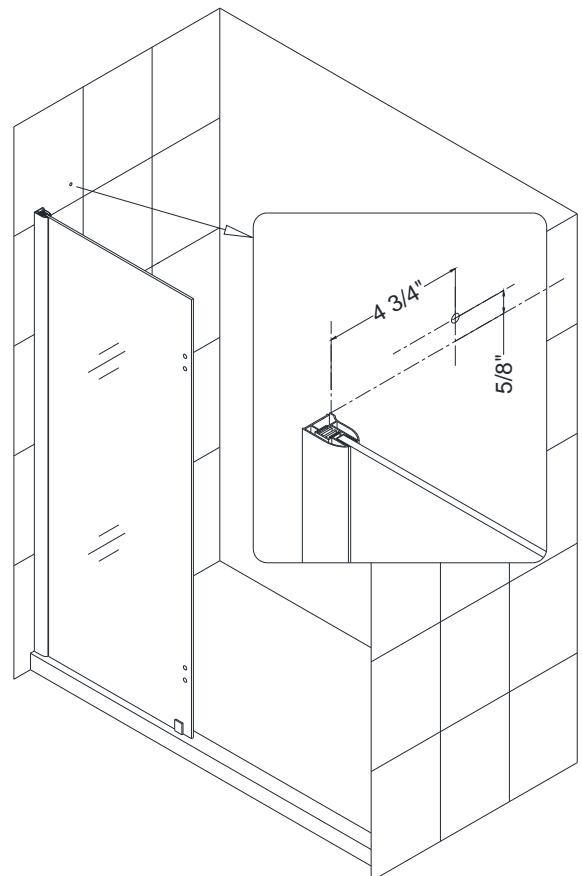

Fig. 8

7. Drill the hole in the wall using $\text{Ø}5/16''$ drill bit and insert **Wall anchor (07)**. Remove the bracket from **Support bar (03)** and attach it to the wall with **Round head screw ST4.2×30(10)**.

See Fig. 9 for details.

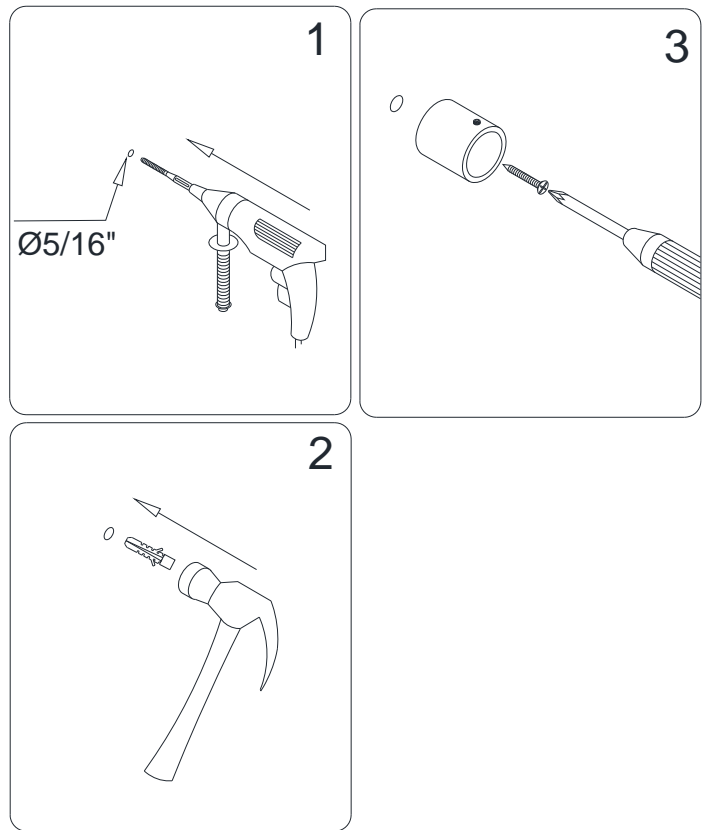

Fig. 9

8. Place the **Support bar (03)** with channel on the **Stationary glass (02)** and insert the other end into the bracket. Tighten the set-screws provided at both ends of the **Support bar (03)**.

See Fig. 10 and Fig. 11 for details.

NOTE: Make sure to use clear rubber gasket to prevent glass to metal connection.

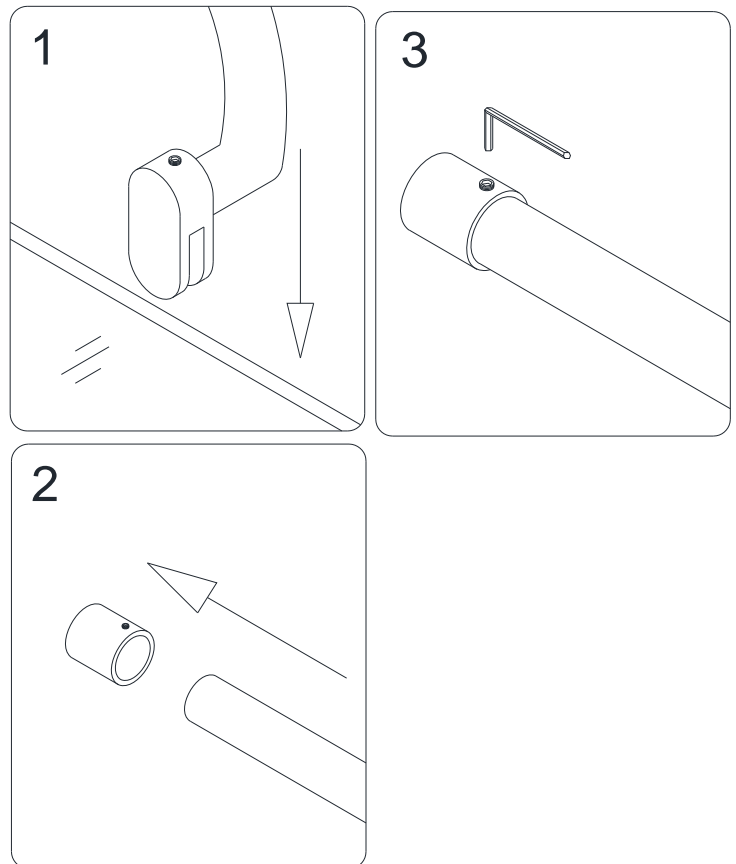

Fig. 10

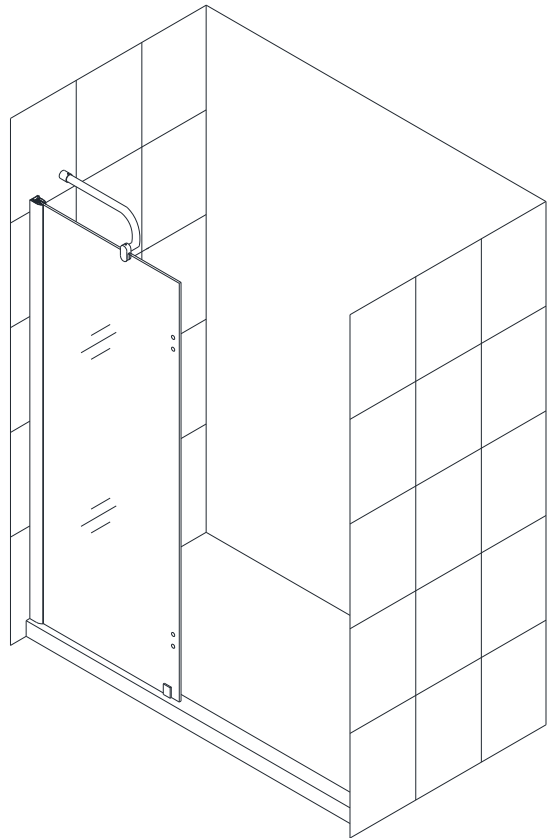

Fig. 11

9. Install the **Hinges (04)** on the **Stationary glass (02)** with the decorative non-screw side facing outwards. Hang the **Glass door (05)** from the inside. You will need assistance in this process.

NOTE: Use clear rubber gasket to prevent glass to metal connection.

Start first from the top hinge when you begin to hang the door on. Make sure that until both hinges are installed securely, do not swing around or lean/bend to any side the Glass door because this can cause the hinge to snap and breakage of the glass.

After the hinges are installed open and close the door to make sure it's operation is nice and smooth. Perform necessary adjustment to have the top edge of the door aligned with the stationary glass.

See Fig. 12 and Fig. 13 for details.

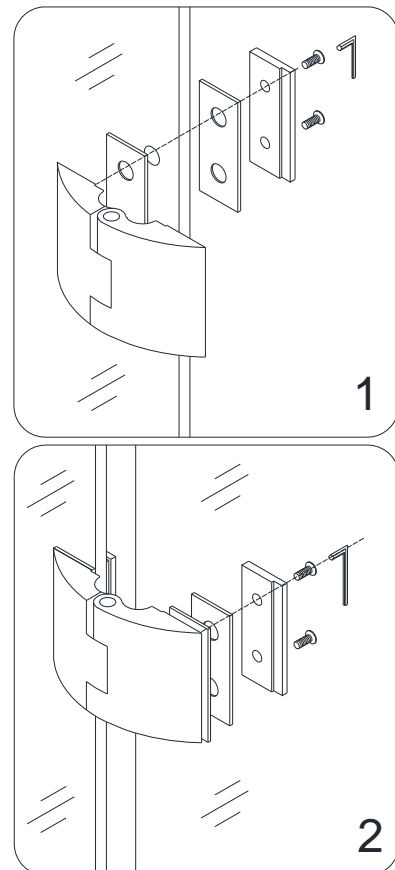

Fig. 12

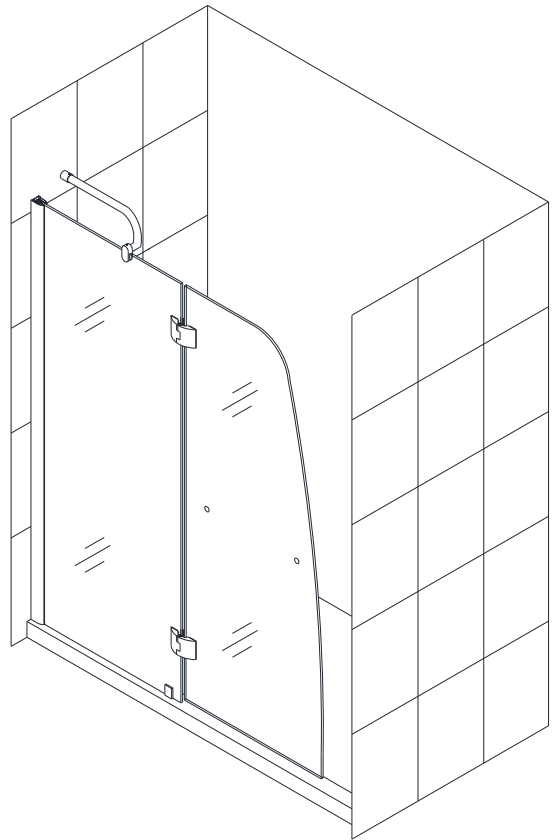

Fig. 13

10. Install the **Handle (06)** onto the **Glass door (05)**.

Attach the **Connected anti-water strip (11)** over the vertical edges of the **Glass door** and the **Stationary**.

Push the **Bottom anti-water strip (12)** to the glass door.

Attach the **Bottom anti-water strip (12)** over the bottom edge of the **Glass door**.

See Fig. 14 for details.

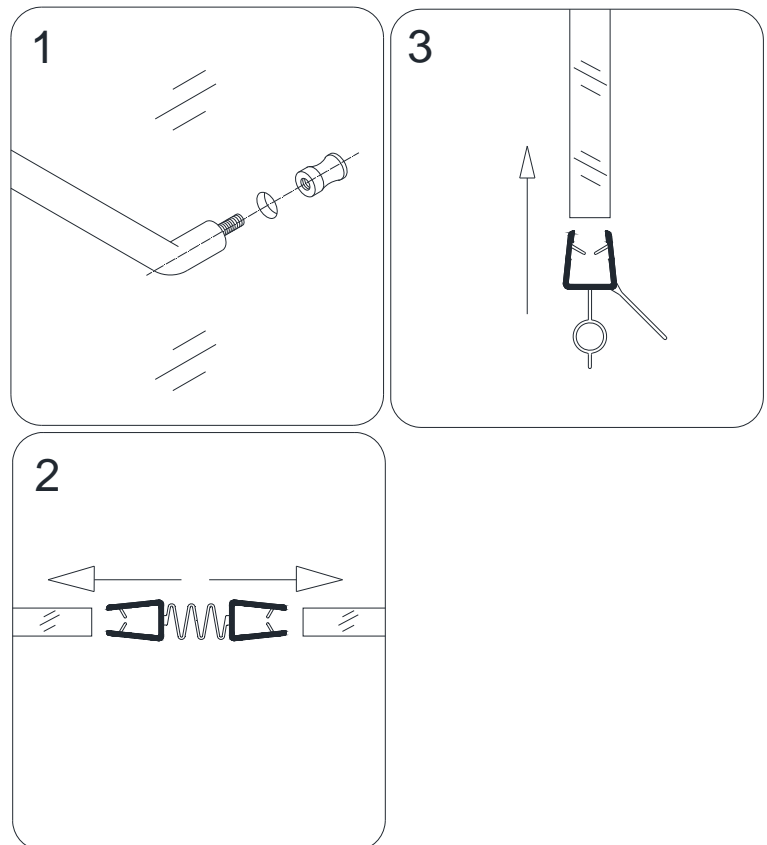

Fig. 14

11. Apply caulk inside and outside along bottom and vertical edge of the stationary glass and wall profile.

See Fig. 15 for details.

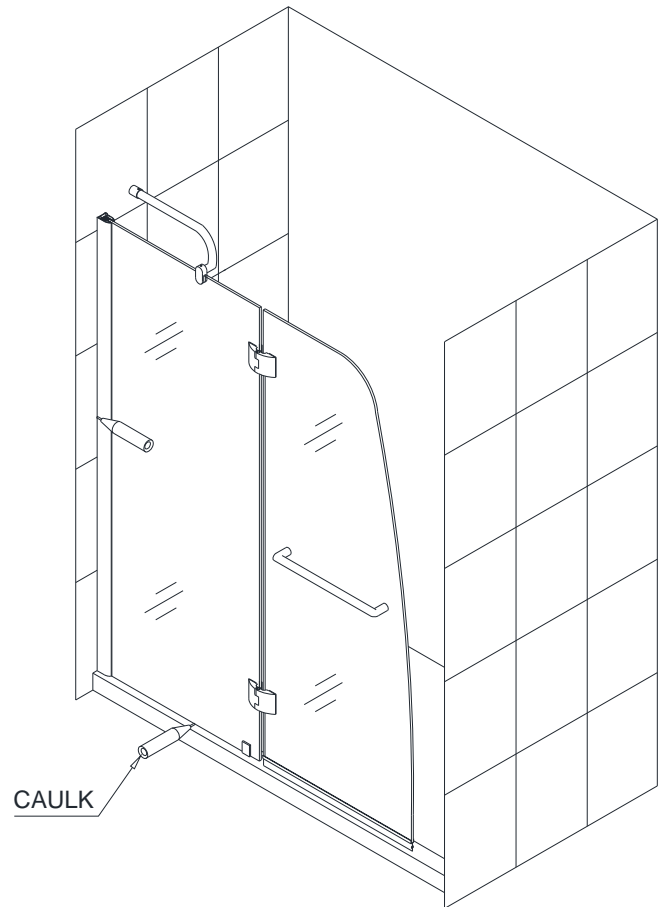

Fig. 15

Product maintenance

To insure long lasting life for your acrylic back walls, wipe them off after each use with a soft cloth. To clean the acrylic back walls use non-abrasive sprays or cream based cleaners. Never use abrasive cleansers, metal brushes or scrapers that could scratch or dull the surface.

To insure long lasting life for your glass shower products, wipe them off after each use with a soft cloth. Rinse and wipe of the glass using either soft cloth or squeegee to prevent soap buildup. Never use abrasive cleaners and cleaning products that contain scoring agent because this may scratch the surface. Never use bristle brushes or abrasive sponges.

To assure a long lasting finish wipe off the metal parts after each use with a soft cloth. Do not use abrasive cleaners or cleaning products containing ammonia, bleach or acid. If accidentally used, rinse the surface as soon as possible to prevent finish peeling or corrosion. After cleaning the shiny finishes, rinse thoroughly and wipe dry with soft cloth. Clean stainless steel surfaces at least once a week. When applying stainless steel cleaner or polish, work with (not across) the grain. Never use abrasive sponge or cloth, steel wool or wired brushes.

DREAMLINE™ LIMITED WARRANTY

This is Bath Authority LLC's ("DreamLine™") exclusive written warranty effective April 2, 2012

This warranty extends only to the original owner/end-user for household use only and is not transferable to a subsequent owner. This warranty applies only to DreamLine™ products purchased from an authorized dealer and installed in United States or Canada. Proof of purchase (original sales receipt) must be provided with all warranty claims. **In no event shall the liability of DreamLine™ exceed the purchase price of the unit.**

If DreamLine™ shower & tub doors, shower enclosures and shower bases are used commercially, DreamLine™ warrants such products to be free from defects in material and workmanship for one (1) year from initial date of purchase from an authorized dealer, with all other terms of this warranty applying except duration. If DreamLine™ vanities, vessel sinks and shower columns are used commercially, DreamLine™ warrants such products to be free from defects in material and workmanship for three (3) months from initial date of purchase from an authorized dealer, with all other terms of this warranty applying except duration. **DreamLine™ Jetted and Steam Shower Cabins are not intended for commercial use and there is no warranty extended for these products for commercial use.**

DreamLine™ hereby disclaims all warranties for products sold as dealer or store displays. DreamLine™ hereby disclaims all warranties for products used outside of the United States or Canada whether expressed or implied, including but not limited to the implied warranties of merchantability and fitness for a particular purpose.

DreamLine™ will, at its election, repair, replace with product of equal value or make appropriate adjustment where DreamLine's analysis or inspection of warranty claim discloses any such defects occurring in normal usage within the warranty period. DreamLine warranty obligation shall be discharged upon tender of replacement or repair. Purchaser's refusal to accept the tender terminates warranty obligation.

Cost of freight for returning products to DreamLine™ for repairs or replacement under this limited warranty are the responsibility of the customer. Cost of freight associated with shipping of replacement product or parts to the customer may be charged to customer. Any product replaced or repaired during the warranty period will be covered only for the remaining period of the original warranty. In no event will DreamLine be liable for costs of repair or replacement of any installation material, including but not limited to tiles, marble, etc. **DreamLine™ is not responsible for installation, removal or reinstallation costs of any product requiring warranty services.**

Improper modification or alteration of any DreamLine™ products will void the warranty. DreamLine product installations and repairs must be performed by either a DreamLine authorized agent or a licensed experienced professional contractor - installation or repairs performed by any other party shall void the warranty. This warranty shall not apply to breakage or damages caused by normal wear and tear, fault, carelessness, abuse, misuse, misapplication, improper maintenance, alteration or modification of the unit, as well as chemical or natural corrosion, accident, fire, flood, act of God or any other casualty. Improper care and cleaning will void the warranty. Use of cleaners containing abrasive cleansers, ammonia, bleach, acids, waxes, alcohol, solvents or other products not recommended for chrome or similar finish, glass or acrylic will void the warranty. For additional product maintenance instructions please refer to product installation manual. DreamLine™ is not responsible for any issues arising in connection with errors or omissions in information provided on DreamLine's websites. The warranty does not extend to any non-DreamLine™ plumbing or components installed by installers, end users or by any party other than DreamLine™.

THE FOREGOING WARRANTIES ARE IN LIEU OF ALL OTHER WARRANTIES, EXPRESSED OR IMPLIED, INCLUDING BUT NOT LIMITED TO THE IMPLIED WARRANTIES OF MERCHANTABILITY AND FITNESS FOR A PARTICULAR PURPOSE. BATH AUTHORITY LLC ("DREAMLINE™") AND/OR SELLER DISCLAIM ALL LIABILITY FOR SPECIAL, INCIDENTAL OR CONSEQUENTIAL DAMAGES. DREAMLINE™ IS NOT LIABLE FOR PERSONAL INJURIES OR DEATH TO ANY PERSON OR FOR ANY DIRECT, SPECIAL, INCIDENTAL OR CONSEQUENTIAL DAMAGE, LOSS OF USE, LOSS OF TIME, LOSS OF PROFITS, INCONVENIENCE, INCIDENTAL EXPENSES, LABOR OR MATERIAL CHARGES, OR ANY OTHER COSTS RESULTING FROM THE USE OF ITS PRODUCTS OR PERTAINING TO THE APPLICATION OF THE PRESENT WARRANTY, OR RESULTING FROM THE REMOVAL OR REPLACEMENT OF ANY PRODUCT OR ELEMENT OR PART COVERED BY THIS WARRANTY.

DreamLine™ is not responsible for product code compliance or for verifying building code restrictions on installation or use and any such compliance is excluded from this warranty. DreamLine™ reserves the right to modify this warranty at any time - such warranty modification will not alter warranty applicable at the time of sale of the products in question. The warranty terms for specific products are:

SHOWER & TUB DOORS, SHOWER ENCLOSURES AND SHOWER BASES

DreamLine™ warrants shower & tub doors, shower enclosures and shower bases to be free from defects in workmanship and materials under normal residential use for a period of five (5) years from the initial date of purchase by the owner/end-user, contractor or builder from an authorized dealer.

SHOWER CABINS (JETTED & STEAM)

DreamLine™ warrants glass, acrylic and finish to be free from defects in workmanship for a period of five (5) years from initial date of purchase by the owner/end-user, contractor or builder from an authorized dealer; and plumbing, electrical and steam generator components for a period of one (1) year from the initial date of purchase by the owner/end-user, contractor or builder from an authorized dealer.

SHOWER COLUMNS

DreamLine™ warrants shower columns to be free from defects in workmanship and materials under normal residential use for a period of one (1) year from the initial date of purchase by the owner/end-user, contractor or builder from an authorized dealer.

VANITIES AND VESSEL SINKS

DreamLine™ warrants bathroom vanities and vessel sinks to be free from defects in workmanship and materials under normal residential use for a period of one (1) year from the initial date of purchase by the owner/end-user, contractor or builder from an authorized dealer.

Some states/provinces do not allow limitations on how long an implied warranty lasts, or the exclusion or limitation of special, incidental or consequential damages, so these limitations and exclusions may not apply to you. This warranty gives you specific legal rights. You may also have other rights, which vary from state/province to state/province.



TEL: 866-731-8378 – 215-957-1411

FAX: 866-227-9245 – 215-893-1780

WWW.BATHAUTHORITY.COM

For more information on [DreamLine™ Shower Door](#) and [Tub Door](#) please visit www.BathAuthority.com